



**"Results You Can Count On"**

**Model 800-8-212-TP100-25**  
**Gfast 8-Channel Loop Simulator**  
**Repeatable Production Testing Solution**

**Ideal for testing Gfast Profile 106 and Profile 212.**



*Model 800-8-212-TP100-25 (8 Channels, 25m, Fixed Length)*

**Introducing the world's first commercially available Production Gfast Loop Simulator.**

Telebyte's Model 800-8-212-TP100 is the world's first commercially available Production Gfast simulator. This 8-channel product utilizes a passive design that features a very low noise floor, providing realistic, repeatable test results. Users can extend line lengths by jumpering from channel-to-channel and/or unit-to-unit.

**Features Include:**

- Simulation of TP100 as defined by BBF WT-285 issue 2 (Attenuation, Impedance, Group Delay)
- Bandwidth DC to 240 MHz
- 8 independent channels (25m, fixed length, twisted pair)
- 65dB isolation between channels for 8 independent loops
- Passive design provides very low noise floor of < -160 dBm/Hz
- Reliable and repeatable test results
- Supports testing of Reverse Power Feeding
- 1U rack-mountable standalone chassis
- Modular design allows for expansion to build dense configurations
- Extend length by cascading from channel-to-channel or through unit-to-unit jumpering
- Automate variable loop lengths by integrating with Telebyte's 600 Series Switch Modules
- Ideal for many applications including production testing, aftermarket services and bonding



"Results You Can Count On"

## Specifications

Series Specifications	
<b>Simulation</b>	<ul style="list-style-type: none"> <li>Simulates TP100 as defined in Broadband Forum's WT-285, Issue 2, Revision 5, Annex E, June 2018</li> <li>Simulates attenuation, impedance, group delay.</li> </ul>
<b>Bandwidth</b>	DC to 240 MHz
<b>Average Noise Floor</b>	< -160 dBm/Hz
<b>Attenuation (Insertion Loss)</b>	MAE < 0.5dB (2MHz to 212MHz) Maximum Attenuation up to 90dB
<b>Impedance</b>	Complex, varies over frequency with length
<b>Group Delay</b>	Better than 5%
<b>DC Rating</b>	± 60 V between Tip and Ring and 350mA
<b>Dimensions</b>	[1U] W 19 in x H 1.75 in x D 24 in (W 482 mm x H 44 mm x D 609 mm)
<b>Mounting options</b>	Mountable in 19" rack
<b>Connectors</b>	16 RJ45 female on front (1 in, 1 out per channel)

Specifications are subject to change without notice. Made in USA.

## Ordering Options

Model	Description
800-8-212-TP100-25	Gfast 8-Channel 25m Fixed Length Loop Local Simulator

*Brought to you by the worldwide leader  
in Gfast Physical Layer Testing Solutions.*



“Results You Can Count On”

**Examples**

**Gfast Production Testing**  
 24 Channels, 25m each

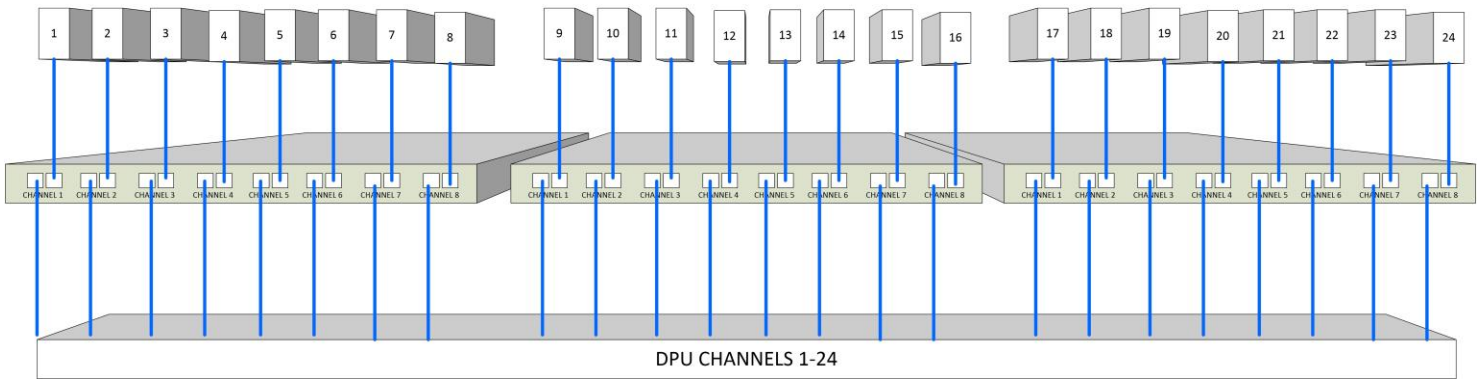

**BONDING TWO 100-METER LINES**

